

## 26 mm Dome Tweeter

## D3004/606005

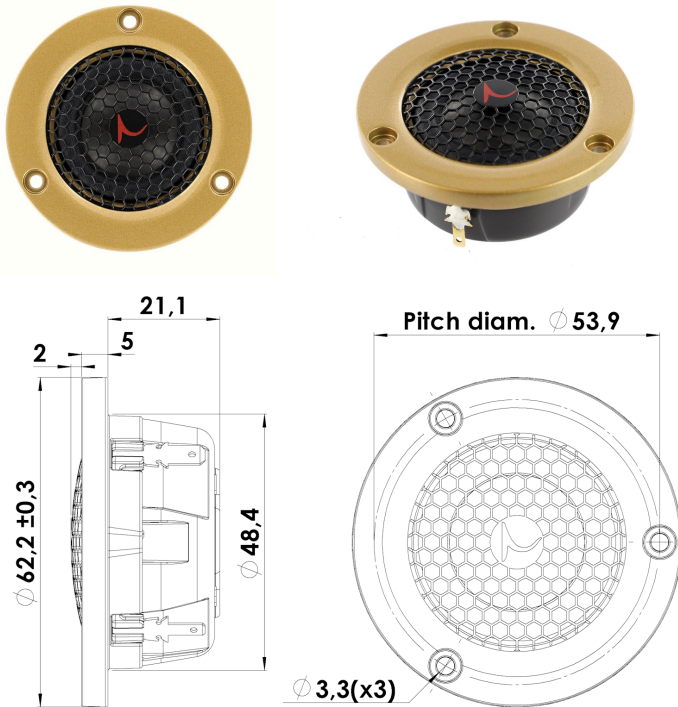

### T-S Parameters:

Resonance frequency [fs]	700 Hz
Mechanical Q factor [Qms]	1.75
Electrical Q factor [Qes]	0.79
Total Q factor [Qts]	0.54
Force factor [Bl]	2.4 Tm
Mechanical resistance [Rms]	0.89 kg/s
Moving mass [Mms]	0.355 g
Compliance [Cms]	0.146 mm/N
Effective diaph. diameter [D]	30 mm
Effective piston area [Sd]	7 cm <sup>2</sup>
Equivalent volume [Vas]	0.01 l
Sensitivity (2,83V/1m)	91 dB

### Mechanical Data:

Voice coil diameter	26 mm
Voice coil height	2.0 mm
Voice coil layers	2
Gap height	2.5 mm
Linear excursion	± 0.25 mm
Max mech. excursion	± 1.6 mm
Unit weight	0.15 kg
Cabinet Displacement Volume	0.03 l

### Electrical Data:

Nominal impedance [Zn]	4 Ω
Minimum impedance [Zmin]	3.4 Ω
Maximum impedance [Zo]	14.7 Ω
DC resistance [Re]	2.9 Ω
Voice coil inductance [Le]	0.03 mH

### Power Handling:

100h RMS noise test (IEC 18.4)	50 W
Long-term max power (IEC 18.2)	100 W
X-over: 2. order HP Butterworth, 2.5 kHz	

### Key Features:

- Bespoke manufactured Thin Ply Carbon Fiber diaphragm
- Large Roll Surround f. wide dispersion
- High Power Patented SD-2 magnet system
- Compact non-Resonant Alu Rear Chamber
- Die Cast housing & Face Plate
- Sound Transparent Protective Grill

### Recommendations (please see Tech Note):

- Operating frequency range: 2500-40000
- Cabinet volume - closed box: N.a.
- Cabinet volume - vented box: N.a.

